

PLAN VIEW
(SCALE 1:16)

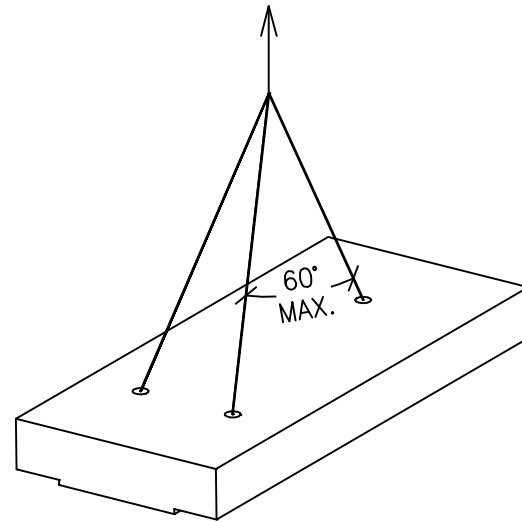

DEMOULDING DIAGRAM FOR LID
(MIN. CONCRETE STRENGTH 15MPa.)

NOTES:

- DESIGNED AND MANUFACTURED IN ACCORDANCE WITH NZS 3101:2006 (PRECAST UNITS) & NZS 3109:1997 AND NZTA BRIDGE MANUAL WITH HN-HO-72 LOADING.
- ALL REINFORCING BARS SHALL BE GRADE 500E TO AS/NZS 4671 UNLESS NOTIFIED OTHERWISE.
- CONCRETE STRENGTH IS 50MPa.
- DESIGNED FOR 100 YEARS LIFE.
- EXPOSURE CLASSIFICATION B1/B2 WITH CONCRETE COVER:
 - 35mm TO OUTSIDE SURFACES
 - 40mm TO INSIDE SURFACES
- ALL DIMENSIONS ARE NOMINAL AND REGIONAL DIFFERENCES MAY OCCUR.
- SURFACE FINISH TO NZS 3114:1987
 - FORMED SURFACE - F4 FINISH
 - TOWELLED SURFACE - U3 FINISH
- FILL COVER ON TOP OF THE LID - 0mm

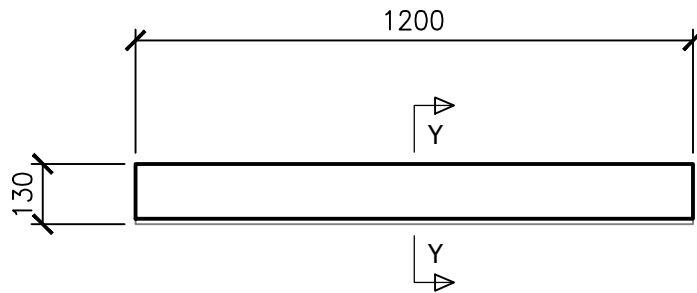

SIDE VIEW
(SCALE 1:16)

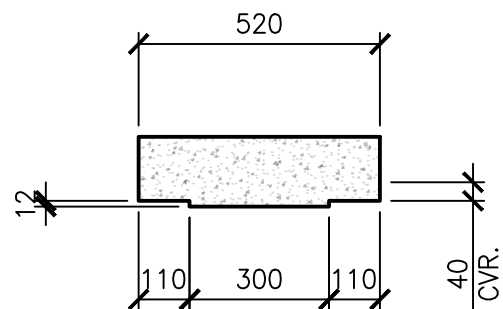

SECTION Y-Y
(SCALE 1:16)

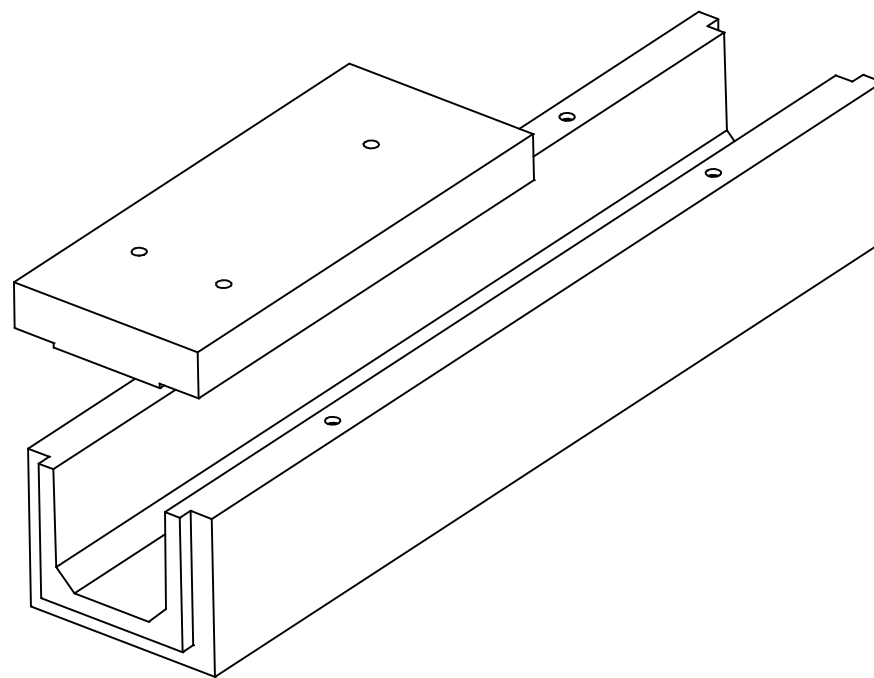

ISOMETRIC
(GENERAL ARRANGEMENT ASSEMBLING)

LIFTING NOTES:

- CHAINS SHALL BE PROPORTIONED TO ENSURE THAT THE ANGLE FROM THE HORIZONTAL IS GREATER THAN 60°.
- CHAIN LENGTH SHALL BE EQUAL TO ENSURE UNIT DOES NOT ROTATE. TO ACHIEVE THIS WE WILL REQUIRE THE HOOK POSITION TO BE LOCATED ABOVE THE CENTRE OF GRAVITY, FINE TUNING OF CHAIN LENGTHS MAY BE REQUIRED.
- LIFT WITH CARE.
- DESIGN ASSUMES A DYNAMIC FACTOR OF 1.2 FOR ONSITE LIFTING. THE PERSON RESPONSIBLE FOR SITE LIFTING SHALL ENSURE THAT THE CONDITIONS STATED IN THE WORKSAFE 'GOOD PRACTICE GUIDELINE FOR SAFE WORK WITH PRECAST' FOR THIN WALLED CIVIL PRODUCTS ARE COMPLIED WITH.



MAXIMUM 60 DEGREES
SLING ANGLE WHEN LIFTING

FOR INFORMATION ONLY

This drawing is the property of Fletcher Concrete & Infrastructure Limited and is subject to return upon demand. It is submitted for use only in connection with proposals and contracts of Humes Pipeline Systems, a division of Fletcher Concrete & Infrastructure Limited upon the express condition that it is not to be reproduced or copied in any form. Data is to be used only with reference to products manufactured and supplied by Humes Pipeline Systems, a division of Fletcher Concrete & Infrastructure Limited.

CODE: 80099867



Humes
Private Bag 92817
Auckland
Freephone 0800 502 112
www.humes.co.nz

CONFIDENTIAL
(NOT TO BE DISCLOSED TO ANY OTHER PERSON WITHOUT PERMISSION FROM FLETCHER CONCRETE & INFRASTRUCTURE LIMITED. UNAUTHORISED DISCLOSURE MAY RESULT IN PROSECUTION)

VOLUME:
0.08 m³
WEIGHT:
0.20 TONNE

Rev	Description	Date	By	Chkd	Product: CONCRETE DUCTING	Details: 300 SERIES	Drawn: SH
A	FOR INFORMATION ONLY	15.01.19	SH	SL	Legacy Code: 04510	Scale: DO NOT SCALE	Checked: SL
B	FILL COVER NOTE ADDED	19.03.21	SH	SL	Project Name		Approved: JN
					HN-HO-72 CONCRETE DUCTING LID		ERF Job No. H17062704.01
					300 SERIES		Costing No. N/A
					PRODUCT DETAILS - FOR SALES		D586-SALE B
					Dwg Title: SHEET 1 OF 1		Dwg. No. Rev.