



# RAIN GARDEN SURROUNDS

QUALITY DESIGNED TO  
100 YEARS' SERVICE LIFE

## Installation

### Safety Handling Guides

The swiftlift anchors are provided to the inside of the walls to aid with safe installation. Appropriately rated chains, clutch and lifting beam must be used when handling this units. Refer to Humes safety and handling guide for further details about swiftlift anchors.

FIG. 6 Lifting Diagram

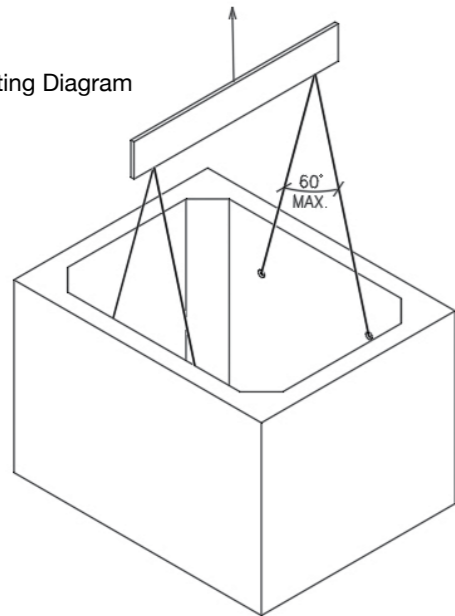

### Lifting notes:

1. Chains shall be proportioned to ensure that the angle from the horizontal is greater than 60°.
2. Chain length shall be equal to ensure unit does not rotate. To achieve this we will require the hook position to be located above the centre of gravity. Fine tuning of chain lengths may be required.
3. Lift with care and brace unit if required.
4. The design assumes a dynamic factor of 1.2 for onsite lifting. The person responsible for site lifting shall ensure that the conditions stated in the worksafe 'good practice guideline for safe work with precast' for thin walled civil products are complied with.



Call 0800 502 112  
Or visit [www.humes.co.nz](http://www.humes.co.nz)

### Applications

New Subdivisions

Individual sites

Car parks

### Product Aspects

Effective and low maintenance

Designed to withstand adjacent HD60 vehicle loading

100 year design life

### Standards

NZS 3109:1997 "Concrete Construction"

NZS 3114:1987 "Surface Finishes"

NZS 3101: Part 1:2006 "Concrete Structures Standard"



Rain gardens are engineered treatment systems designed to harness the natural ability of vegetation and soils for treatment of stormwater runoff. Treatment occurs through sedimentation, filtration, absorption and uptake by vegetation. Rain gardens can be used to reduce the effects of stormwater volumes, peak flows and contaminant loads on waterways.

Humes Rain Garden Surrounds are precast concrete structures that provide the housing for treatment rain garden systems. Humes has a range of standard sizes to suit the varying requirements of a wide range of projects.

### Features

- A modular precast concrete structure designed and manufactured in accordance with the relevant sections of the following standards and specifications where applicable:
  - NZS 3109:1997 "Concrete Construction"
  - NZS 3114:1987 "Surface Finishes"
  - NZS 3101: Part 1:2006 "Concrete Structures Standard"
  - Manufactured at Humes' ISO certified Hamilton plant ISO 9001: 2015 Quality Management Standard
  - Swiftlift anchors positioned on internal walls

### Benefits

- Provides separation between internal filter media and surrounding soil or fill
- Supports lateral loads
- Quick and easy installation compared to cast in-situ concrete construction
- Service life expectation in excess of 100 years
- Available through all Humes North Island Sales Centres.
- Supports safe installation

FIG.1 Typical cross section of Humes Rain Garden Surrounds

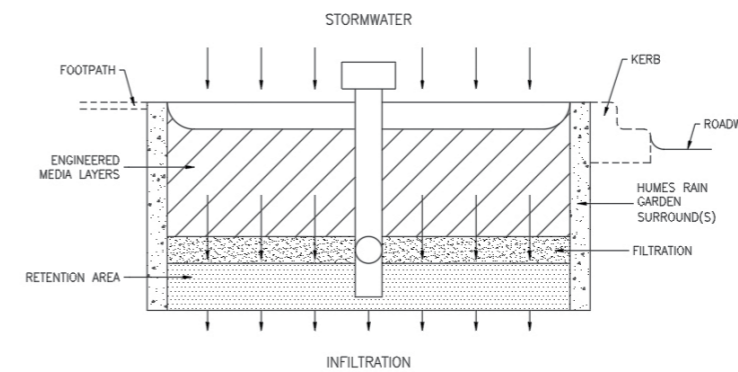

Humes Rain Garden Surrounds

Internal Dimension L	Internal Dimension W	Mass (tonnes)	Lifting Clutches Required (tonnes)	Humes Item Number			
				No Slot	Inlet Slot		
					Left Hand	Right Hand	Centre Slotted
1500	1500	4.2	4x 2.5t	80089687	-	-	80089728
1750	1500	4.4	4x 2.5t	80100384	80100386	80100385	ETO
2000	1500	4.7	4x 2.5t	80089743	80089693	80089679	ETO
2000	2000	5.3	4x 2.5t	80089691	80089757	80089692	ETO
2500	2000	5.9	4x 5t	80089686	80089655	80089753	ETO
2500	2500	6.5	4x 5t	80089699	80089685	80089723	ETO
3000	1500	5.9	4x 2.5t	80089735	80089742	80089718	ETO
3000	2000	6.5	4x 5t	80089646	80089756	80089678	ETO
3000	2500	7.1	4x 5t	80089677	80089684	80089727	ETO

- All dimensions are internal in mm
- Humes Rain Garden Surrounds are designed for HD60 Loading (design live load is 60kN)
- Concrete strength of 50 MPa
- Wall thickness is 150mm and corner chamfer is 200mm x 200mm
- Standard Rain Garden Surrounds depth H is 1550mm
- Customised Rain Garden Surrounds are available on request (ETO)

FIG. 2 Left Hand

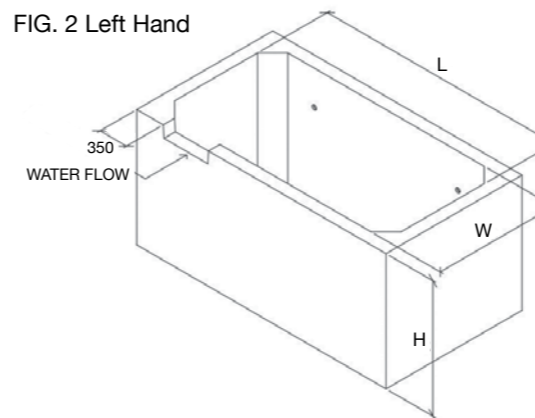

FIG. 3 Right hand

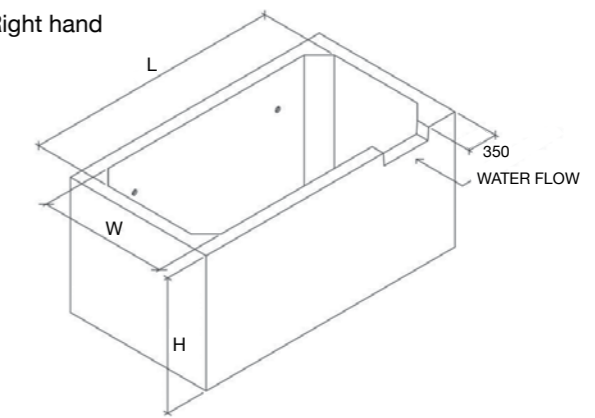

FIG. 4 Centre slotted

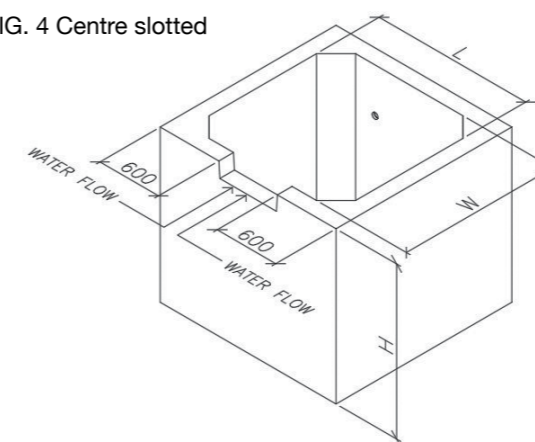

FIG. 5 Inlet slot cut out details

